

## PRINCIPLE OF OPERATION

AS™-Series Ammonia Scrubbers remove ammonia from a gas stream to protect analyzers and sample lines from clogging due to the formation of ammonium salts.

Ammonia reacts with phosphoric acid, forming ammonium phosphate. This relatively high melting point salt immediately deposits inside the ammonia scrubber, removing it from the gas stream. The reaction is quite selective, and does not affect the concentrations of other gases in the stream.

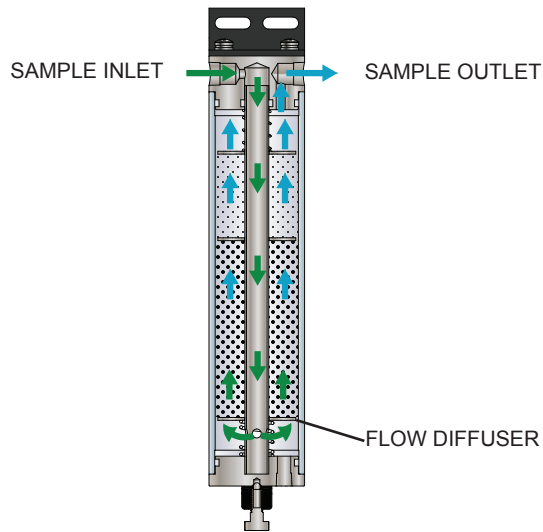
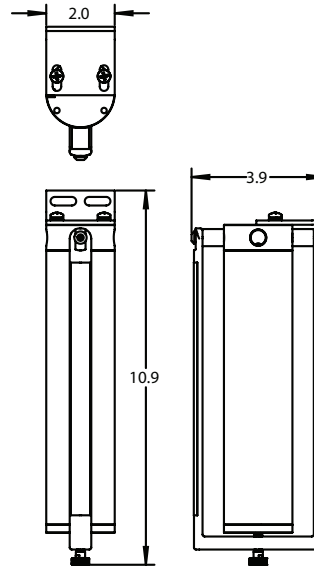

**Figure 1 - Flow Schematic**

Phosphoric acid is very hygroscopic so it will draw water from the gas stream, creating some liquid phosphoric acid solution in the bottom of the scrubber. To avoid excess liquid formation, the scrubber should be heated, either by installation in a heated enclosure or by using a heated scrubber.

The AS-Series proprietary scrubber media has been formulated for continuous operation. Its life expectancy is dependent upon the sample flow rate and ammonia concentration in the gas stream. It is very selective in its reactions with the gas, removing only ammonia. It is also a very safe, stable chemical to handle and store.

## MOUNTING ARRANGEMENT



Mount scrubber in a vertical orientation using the angle bracket provided. Connect gas sample lines to the labeled inlet and outlet ports. Be sure to connect sample inlet to port marked "IN" on the scrubber housing.

## AMMONIA SCRUBBER SPECIFICATIONS

Material of Construction	Polysulfone	Stainless Steel
Pressure	30 psig	100 psig
Temperature	120°C	200°C
Port Size	1/4" NPT	1/4" NPT
Operating Environment	-20°C to 40°C Ambient Temp. 0-95% RH	
Power	30W @ 115V ±10% or 230V ±10%	

This equipment is to be installed & operated by trained personnel, with sufficient command of the English language to clearly understand the instructions & safety warnings.

AS™ is a trademark of Perma Pure LLC.  
DOC # SE-MAN-006 REV 01

## AS™ - Series Ammonia Scrubber

### User Manual



**PERMA PURE**

A HALMA COMPANY

1001 New Hampshire Ave, Lakewood, N.J. 08701  
Phone: 732-244-0010 Fax: 732-244-8140  
info@permapure.com www.permapure.com

## PERFORMANCE

The Ammonia Scrubber performance varies depending on the concentration of ammonia and flow rate of the gas sample. At a flow rate of 1 lpm and 1ppm of ammonia, media should last 40,000 hours.



Figure 2

## REPLACEMENT PARTS

Part Number	Description
AS-200-08-PSH	Stainless steel top & bottom with polysulfone shell
AS-200-08-SSH	Stainless steel top & bottom with stainless steel shell
AS-200-3	O-ring replacement set
AS-200-08-EB	1L (15 fillings) replacement burl saddles media

## REPLACING SCRUBBING MEDIA

When deposits are visible 75% of the way up the housing, the scrubbing media needs to be replaced (see Figure 2).

1. Release thumb latch on bottom of housing to disengage yoke.
2. Swing yoke to one side.
3. Separate housing and bottom cap as an assembly from top cap.
4. Remove spring and top baffle.
5. Remove old media and center baffle and dispose of media properly (housing may be rinsed with soapy water to clean).
6. Fill housing with 135cc of burl Saddles (tap housing to allow material to settle).
7. Replace center baffle.
8. Pour 65cc of Scrubbing Media.
9. Replace top baffle.
10. Replace spring.
11. Clean o-rings on shell and inside top manifold (replace if necessary).
12. Place center tube into o-ring seal in top cap.
13. Push and twist to seal housing around o-ring.
14. Replace yoke by swinging back into place and engage the spring plunger once in position.

## WARNING!

Eye Protection & Gloves should be worn when replacing media.

Caution: Allow unit to cool before handling.

## HEATER JACKET SETUP

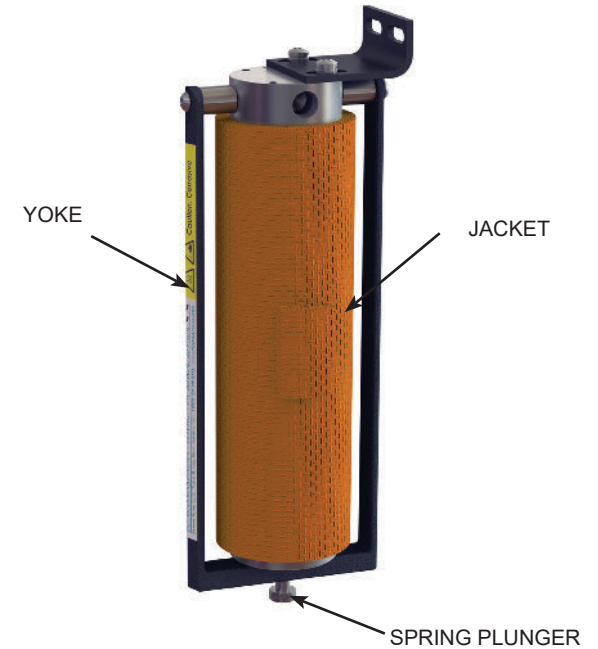
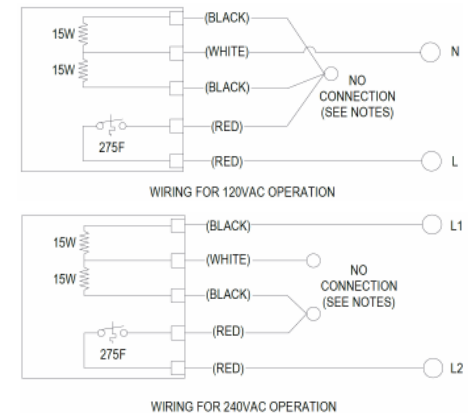

Figure 3

## Power Supply Connection for Heater Jacket

1. Connect 120/240VAC power supply to wires on scrubber (note: white wire must be capped with wire nut since voltage is present when heater is energized in 240VAC operation). See below.
2. Allow heater jacket to run for 15-20 minutes before starting sample flow (heater is equipped with thermocouple and thermostat to regulate heater).



NOTES:

1. WHEN WIRING FOR 120VAC OPERATION, THE BLACK/RED WIRE CONNECTION MUST BE CAPPED PERMANENTLY SINCE VOLTAGE IS PRESENT ON THESE WIRES WHEN THE HEATER IS ENERGIZED.
2. WHEN WIRING FOR 240VAC OPERATION, THE WHITE WIRE AND THE BLACK/RED WIRE CONNECTIONS MUST BE CAPPED PERMANENTLY SINCE VOLTAGE IS PRESENT ON THESE WIRES WHEN THE HEATER IS ENERGIZED.
3. LABEL HEATER JACKET "AS-200-02-20 HEATER JACKET, DUAL VOLTAGE, 120/240 VAC, 30 WATTS, 275F HIGH LIMIT T-STAT"

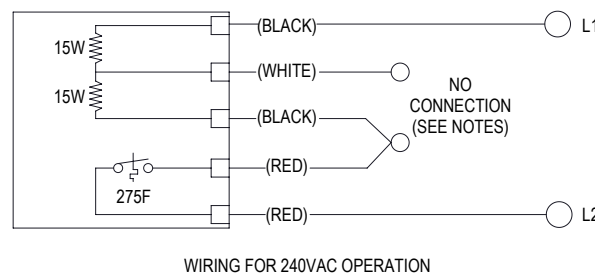
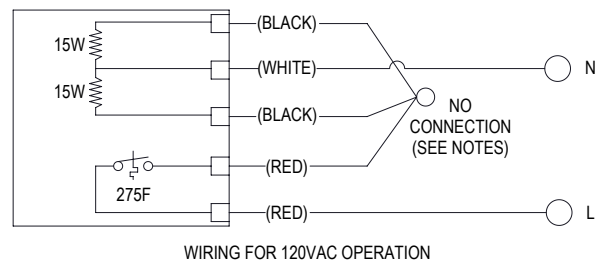
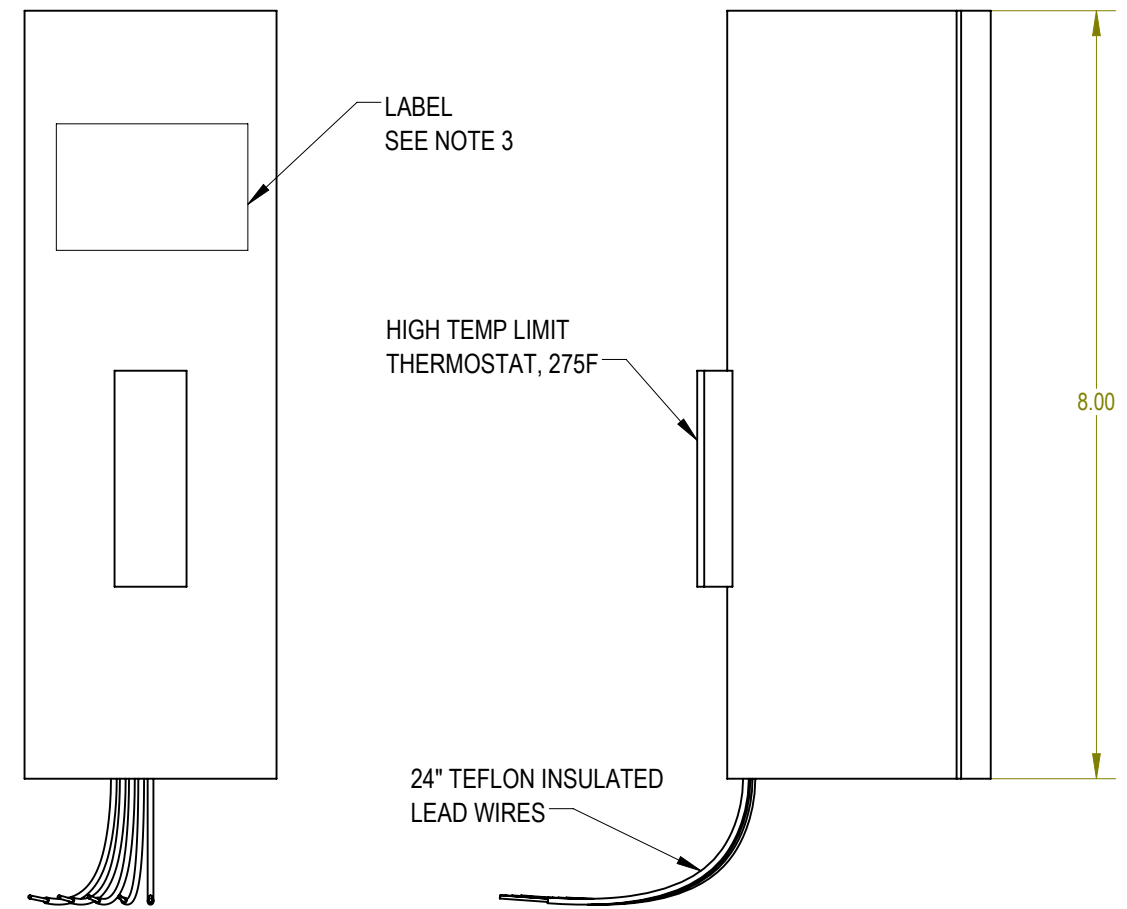
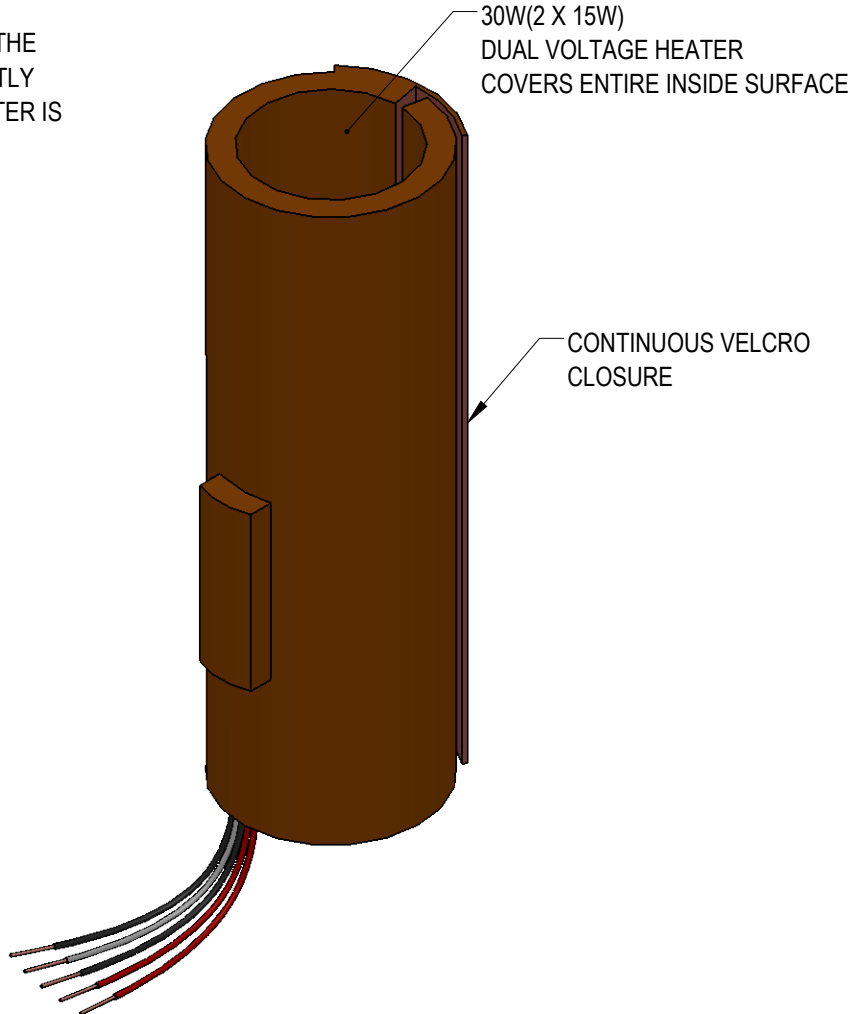
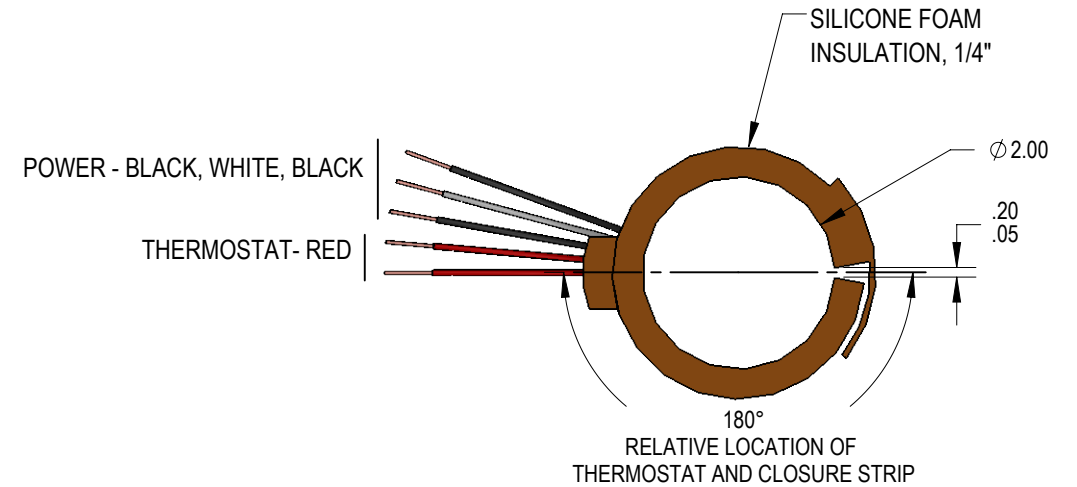

**PROPRIETARY AND CONFIDENTIAL**  
 THE INFORMATION CONTAINED IN THIS DRAWING IS THE SOLE PROPERTY OF PERMA PURE LLC. ANY REPRODUCTION IN PART OR AS A WHOLE WITHOUT THE WRITTEN PERMISSION OF PERMA PURE LLC IS PROHIBITED.

-	MATERIAL	-
-	FINISH	-
USED ON OR NEXT	DO NOT SCALE DRAWING	

APPROVAL	RL	1/2/2018
DRAWN BY	-	-
UNLESS OTHERWISE SPECIFIED: DIMENSIONS ARE IN INCHES TOLERANCES: FRACTIONAL & .X DECIMAL ± .03 .XX DECIMAL ± .01 .XXX DECIMAL ± .005 ANGULAR: ± 1°		

**PERMA PURE LLC**  
 A HALMA COMPANY  
 "Leaders in Gas Conditioning"  
 800.337.3762 www.permapure.com

TITLE:		HEATER JACKET, DUAL VOLTAGE	
SIZE	DWG. NO.	REV	
<b>B</b>	AS-200-02-20	-	
SCALE: 1:2		SHEET 1 OF 1	